

Constant Voltage LED Power Supply

SES24-12VL

SES24-24VL

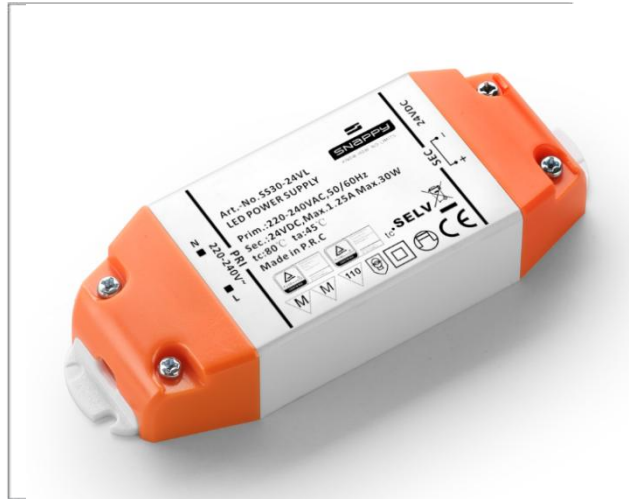

Product description

The SES24 series is a constant voltage LED driver for indoor use with an input voltage range of 198–264Vac. It has up to 86% conversion efficiency, fanless design, and operates in the ambient temperature range of -20°C to $+45^{\circ}\text{C}$. It also has high power factor, ultra-low total harmonic distortion, low standby power consumption, and a full range of protection features that not only greatly improve product reliability, but also ensure the product life cycle. This series of products are designed for LED lighting, designed for indoor and outdoor lighting applications. It is suitable for various applications in almost all indoor locations where LED luminaires can be installed.

Standards

EN61347-1
EN61347-2-13
EN61547
EN55015
EN61000-3-2
EN61000-3-3
EN62493

Characteristics

- European input voltage 220–240VAC
- IP20
- Suitable for dry indoor environment
- Short circuit / over load protection
- Plastic case
- Compliance to worldwide safety regulations for lighting
- Warranty: 5 years

www.snappy.cn

Specifications

Model		SES24-12VL	SES24-24VL
Output	turn on time(S)	<0.5	<0.5
	output power(W)	24	24
	output voltage(V)	12	24
	output voltage tolerance	≤±5%	≤±5%
	ripple voltage(mV)	< 3%	< 5%
	Line Regulation	1%	1%
	Load Regulation	2%	1%
	working current range(A)	0-2	0-1
	SVM	0.1	0.1
	Pst	0.1	0.1
Input	rated DC supply voltage(Vdc)	180-240	180-240
	rated supply voltage(Vac)	220-240	220-240
	voltage range(Vac)	198-264	198-264
	line frequency(Hz)	50/60	50/60
	input current(A)	0.18	0.18
	efficiency	85%@full load	86%@full load
	average efficiency(TYPE) 3	82.4%	84%
	no load power consumption(W)	≤0.5W	≤0.5W
	power factor	0.95@full load	0.95@full load
	Displacement factor	0.95	0.95
	THD(typ.)	4%	5%
	inrush current(Ipk)	30A/300μS	30A/300μS
	Leakage current	0.7@240Vac 60Hz	0.7@240Vac 60Hz
Protection	short circuit protection	hiccup mode, restart automatically after fault correction.	hiccup mode, restart automatically after fault correction.
	over load protection	hiccup mode, restart automatically after fault correction.	exceed maximum rated load times 1.1
	Over voltage protection	Yes(latch off)	Yes(latch off)
	surge capacity	L-N: 500V	L-N: 500V
	Withstand voltage	Input-Output: 3000V/5mA/1min Input-gnd:1500V/5mA/1min	Input-Output: 3000V/5mA/1min Input-gnd:1500V/5mA/1min
Ambient	Ta(C)	-20...45(see fig.2)	-20...45(see fig.2)
	Tc max.(C)	max.85	max.85
	Storage Temperature(C)	-30...80	-30...80

and Life	ambient humidity range	5%...85%RH, Not condensing	5%...85%RH, Not condensing
	nominal life-time(hrs)	50'000@Ta	50'000@Ta
Other	dimensions (L×W×H)(mm)	123x44.6x19.2	123x44.6x19.2
	weight(g)	100	100
	casing material	Plastic	Plastic
	housing colour	White	White
	type of protection	IP20	IP20
	protection class	class II	class II
	certificate		
Note	<p>1.Tolerance:includes set up tolerance, line regulation and load regulation.</p> <p>2.Tested at full load,230Vac.Refer to"Power Factor" and "EFFICIENT"curve graphs.</p> <p>3.Calculate the model's average efficiency for each test voltage by testing at 100%, 75%, 50%, and 25% of rated current and then computing the simple arithmetic average of these four values.</p> <p>4.All parameters NOT specially mentioned are measured at nominal voltage input, rated load and 25 of ambient temperature.</p> <p>5.The power supply is considered as a component that will be operated in combination with final equipment. Since EMC performance will be affected by the complete installation, the final equipment manufacturers must re-qualify EMC Directive on the complete installation again.</p>		

Dimensions(mm)

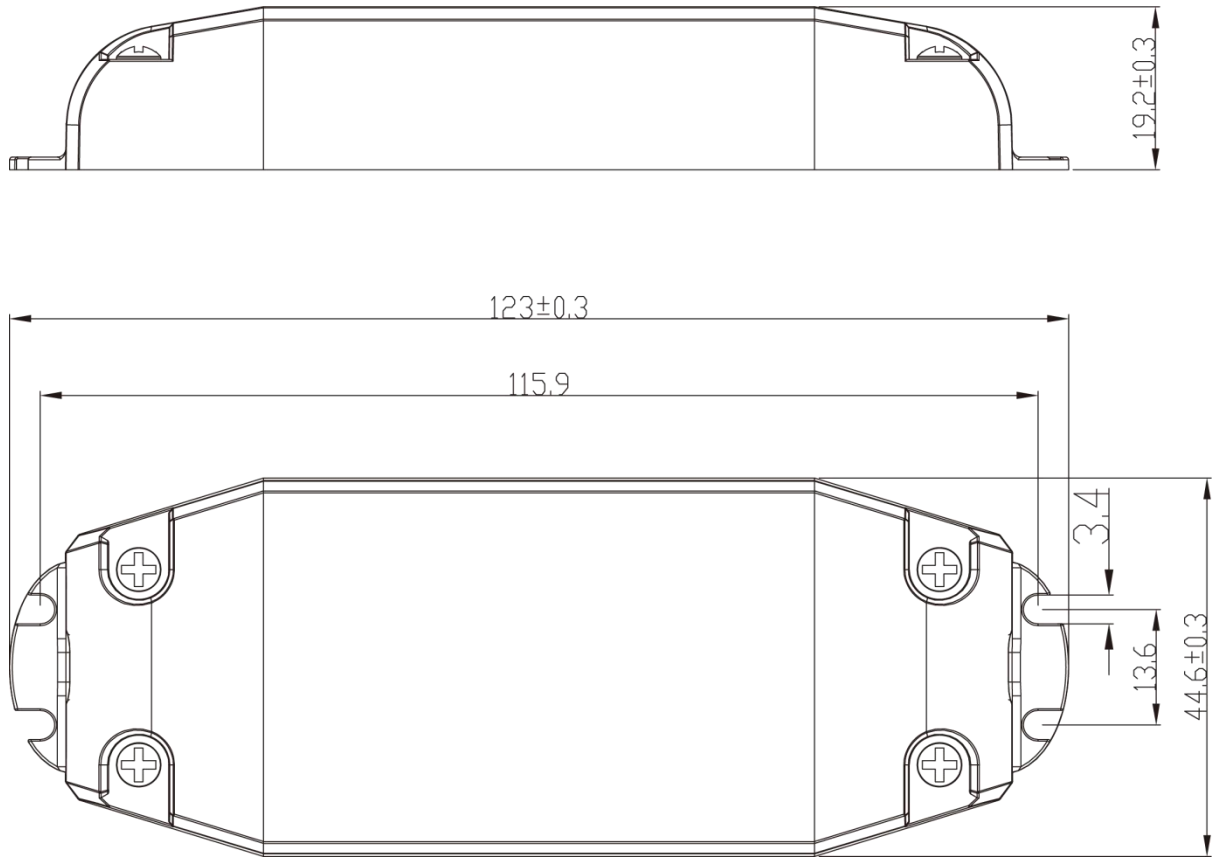

Wiring Diagram

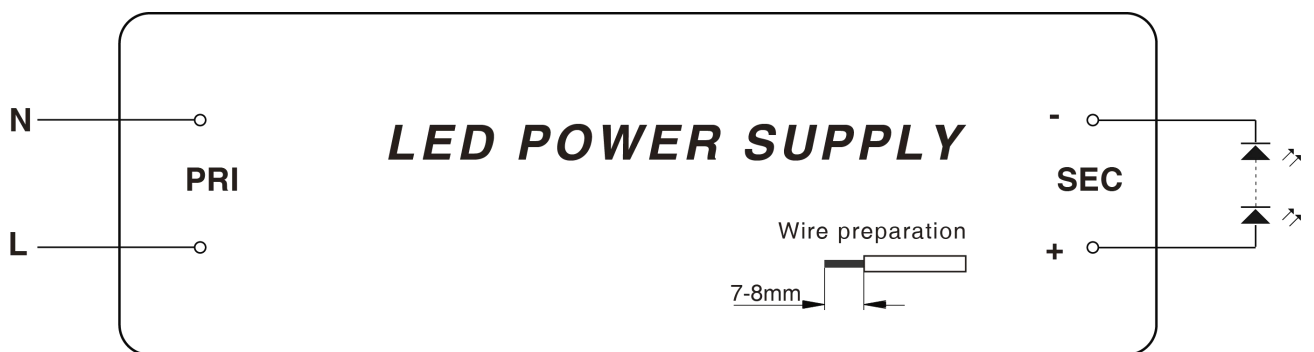

AC	Terminal, H03VVH2-F 2*0.75mm ²
DC	Terminal, H03VVH2-F 2*0.75mm ²

Electrical curves

Fig. 1 Output load-Temperature curve

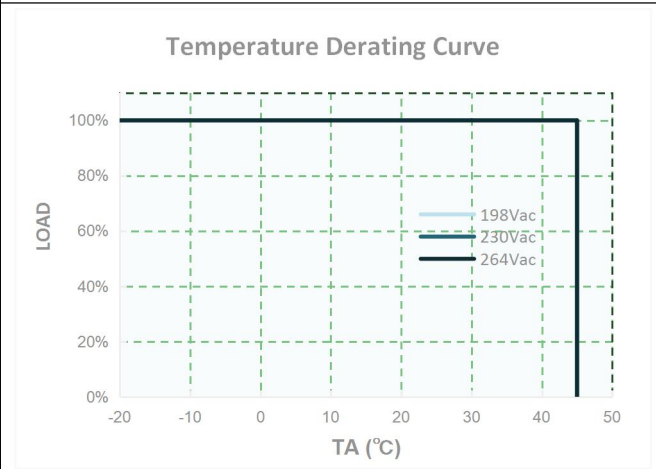

Fig. 2 Static characteristic curve

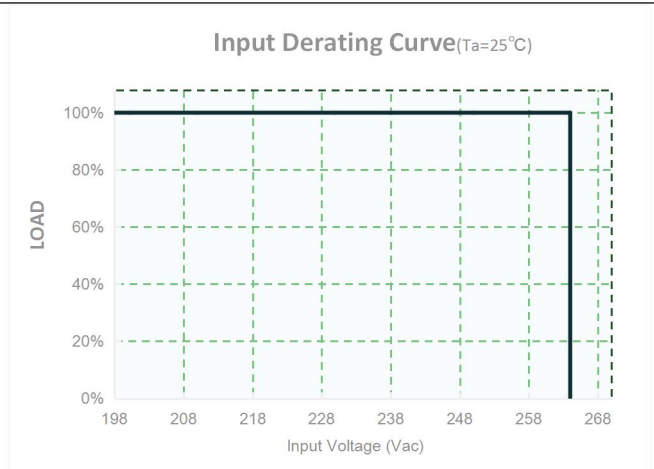

Fig. 3 I-V curve

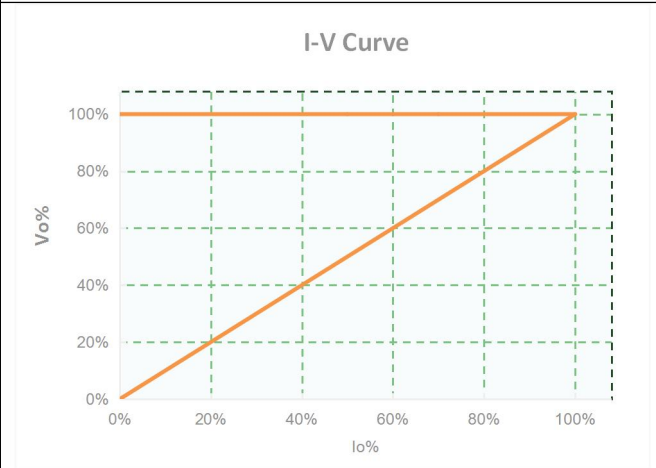

Fig. 4 Power factor characteristic curve

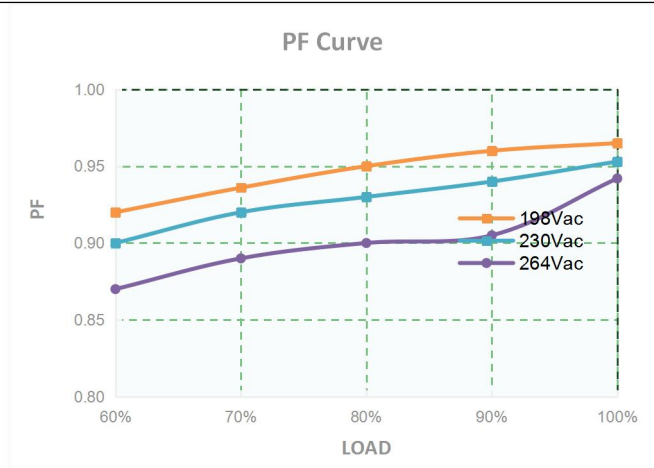

Fig.5 Total harmonic distortion curve (THD)

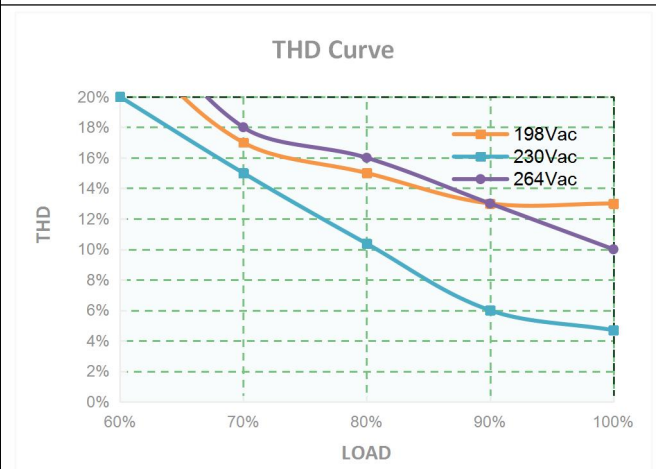
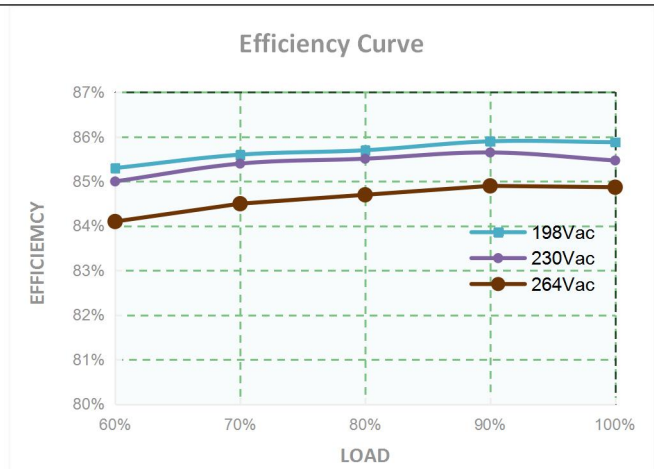

Fig.6 Efficiency-Load curve



MCBS

MCBS Model	B10	B13	B16	B20	C10	C13	C16	C20
SES24-12VL	36	46	57	71	28	37	45	57
SES24-24VL	36	46	57	71	28	37	45	57

Package

Model	Carton quantity(pcs)	Carton dimension(mm)	G.W./CTN(kg)
SES24-12VL			
SES24-24VL			

Revision history

Date	Rev.	Remark
2023.2.28	A1	Initial release.